

W8IO Rooftowers LLC

8 foot Roof Mount Tower DIY Instructions

24 July 2016



TOOLS

First, you will need the following tools at a minimum:

1. 1/2" drill press with these approximate bit sizes - 0.265", 0.295", 0.312", 0.345", 0.375",
2. Table mounted miter saw with a 60 tooth (minimum) 10" carbide tipped blade
3. Tape measure
4. Calipers (either dial or digital)
5. Flat hand file
6. Hand cordless drill with deburring bit

Here is a good video which helps understand how to cut aluminum with a regular miter saw:

<http://www.youtube.com/watch?v=iojOYZw2Vi4>

Bill of Material (B.O.M.)

The following aluminum angle and flats can be purchased from OnlineMetals.com. Look for sales near Holidays.

1. 6 each 2" x 2" x 1/8" x 96" long 6061-T6 angle
2. 1 each 2" x 2" x 1/8" x 24" long 6061-T6 angle
3. 1 each 2" x 2" x 1/4" x 24" long 6061-T6 angle
4. 4 each 1/8" x 2" x 60" flat 6061-T651



The following hardware can be purchased from [Fastenal](http://Fastenal.com), [DX Engineering](http://DXEngineering.com) or your favorite hardware store:

1. 1/4" - 20 x 1" length stainless steel bolt, Qty = 24
2. 1/4" - 20 x 3/4" length stainless steel bolt, Qty = 8
3. 5/16" - 18 x 1" length stainless steel bolt, Qty = 4
4. 1/4" SS split lockwashers, Qty = 32
5. 5/16" SS split lockwashers, Qty = 4
6. 1/4" SS hex nut, Qty = 32
7. 5/16"-18 SS hex nut, Qty = 4
8. 3/8" - 16 x 9" galvanized bolt or SS bolt for roof mounting (approx. length), Qty = 8
9. 3/8" lockwashers, Qty = 8
10. 3/8" - 16 hex nut (SS or galv.), Qty = 8

You will also need a thrust bearing for the top - either the [Yaesu GS-065](http://Yaesu.com) or [GS-050](http://Yaesu.com). The GS-065 will handle 2.5 inch diameter masts while the GS-050 will only handle up to 2.0 inch diameter masts. They have slightly different mounting-hole dimensions.

CUTTING

Four of the 2" x 2" x 1/8" x 96" angles will be used for the 96" legs and will not be cut.

One of the 2" x 2" x 1/8" x 96" angles is cut into 4 each 22" long sections, each with 45 degree inward cuts at each end. These are the 4 lower shelf brackets. Begin with a 45 degree cut (from the edge of the part inward), then measure 22" and mark. Cut on the mark with another 45 degree cut (toward the previous cut). Cut another 45 degree cut from the cut edge inward to begin the second part. Measure 22" and mark. Cut on the mark with another 45 degree cut (toward the previous cut). Repeat until you have 4 parts done. **Hint: Cut just past each mark so you have the correct length after the cut.** These are the lower shelf brackets.



The remaining 2" x 2" x 1/8" x 96" angle is cut into 4 each 15.5" long sections with 45 degree inward cuts at each end. These are the 4 upper shelf brackets. The remaining piece is cut into two 15.5" with square ends. These will be the two rotor mounting shelves.

The 2" x 2" x 1/8" x 24" long angle is cut into 4 each 4.875" long sections with 45 degree inward cuts at each end. These are the thrust bearing brackets for the top of the tower. The Autocad drawing shows these as being exactly 5" long, however I found that a length of 4.875" - 4.938" works better to fit the Yaesu GS-065 thrust bearing. The cut side of the angle will be trimmed to allow a 2.5" diameter mast tube.

The 2" x 2" x 1/4" x 24" long angle is cut into 4 equal length sections with straight cuts. These are the 4 tower Feet, approximately 6" in length.



Each 1/8" x 2" x 60" flat piece is cut into 2 each 30" lengths with straight cuts, ending up with 8 each 1/8" x 2" x 30" flat pieces. (actually 29 15/16" long) These are the diagonal "X" braces.



DRILLING

Please carefully follow these steps to properly drill the holes for your 8 foot roof mount tower parts.

1. The top thrust bearing brackets should be drilled as shown below. The bracket is shown in the drawing as 5.0" in length. It fits together much easier if the length is closer to 4.875".

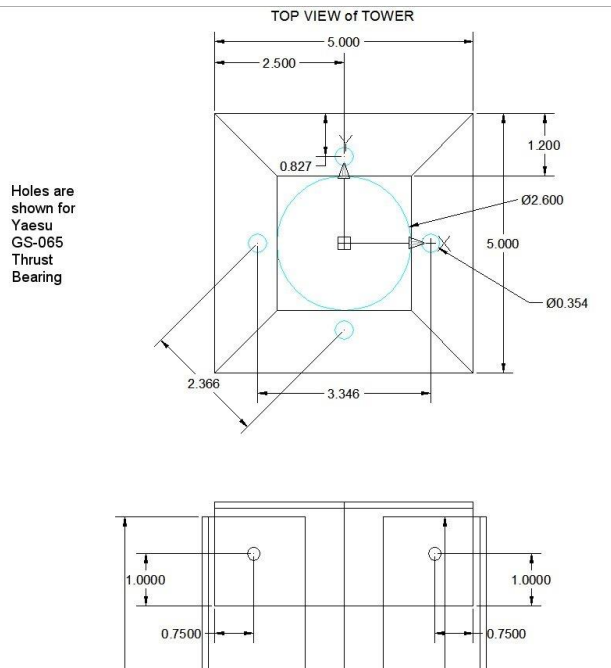

2. The four Upper Shelves are divided into two groups of two. Two shelves have holes drilled for attachment to the Legs and the Rotor Shelf. The two remaining Upper Shelves only have the holes drilled for attachment to the Legs. See the two drawings below.

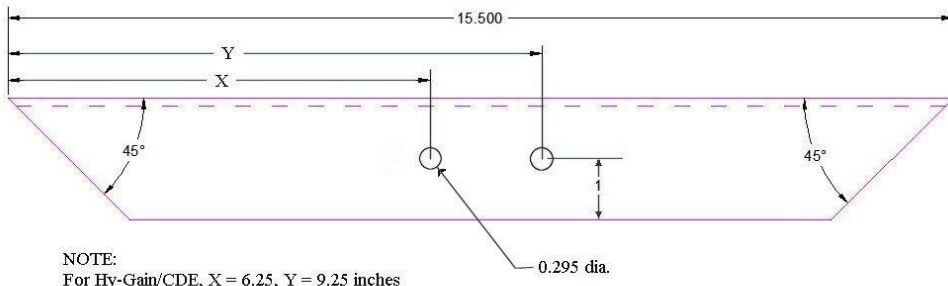

NOTE:
 For Hy-Gain/CDE, X = 6.25, Y = 9.25 inches
 For Yaesu/Kenpro, X = 6.1, Y = 9.41 inches



Upper Shelf with Rotor Shelf Mounting Holes (2)

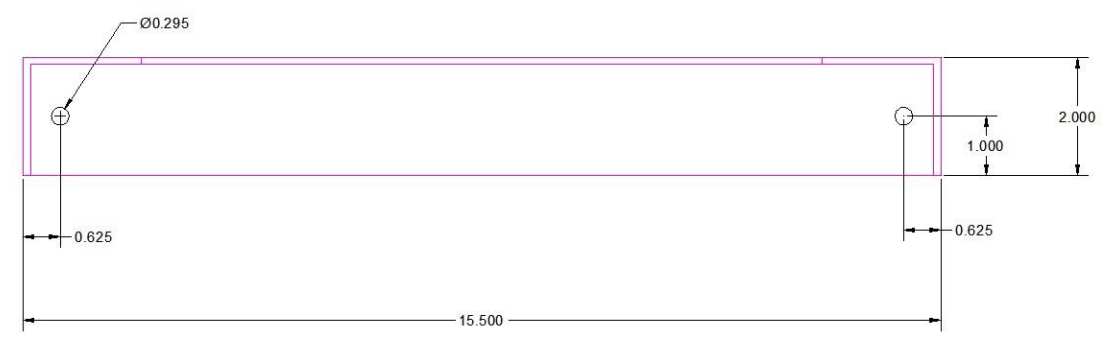
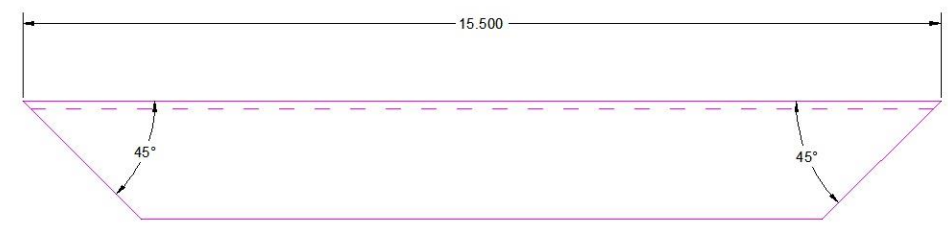

Upper Shelf (2)

3. Drill the holes for the 2 Rotor Mounting Brackets as shown below.

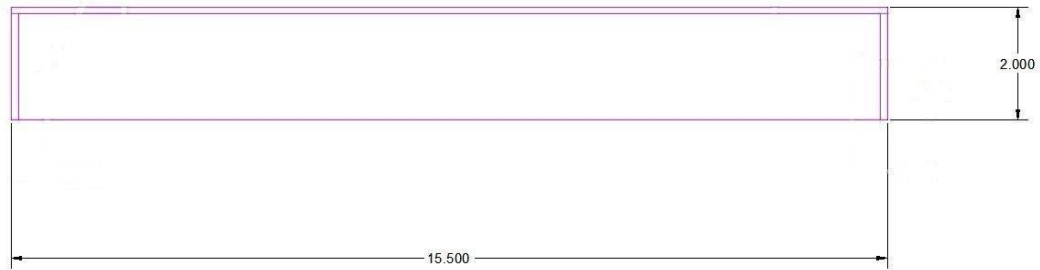
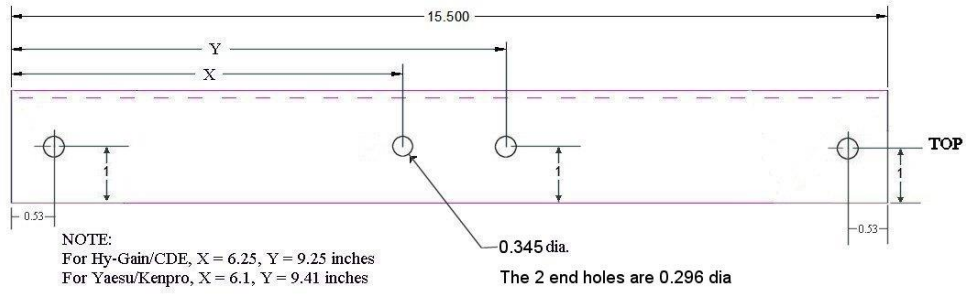

Rotor Mounting Bracket (2)

4. Drill the holes for the 4 Lower Shelf Brackets as shown below. Holes are 0.625" from each end.

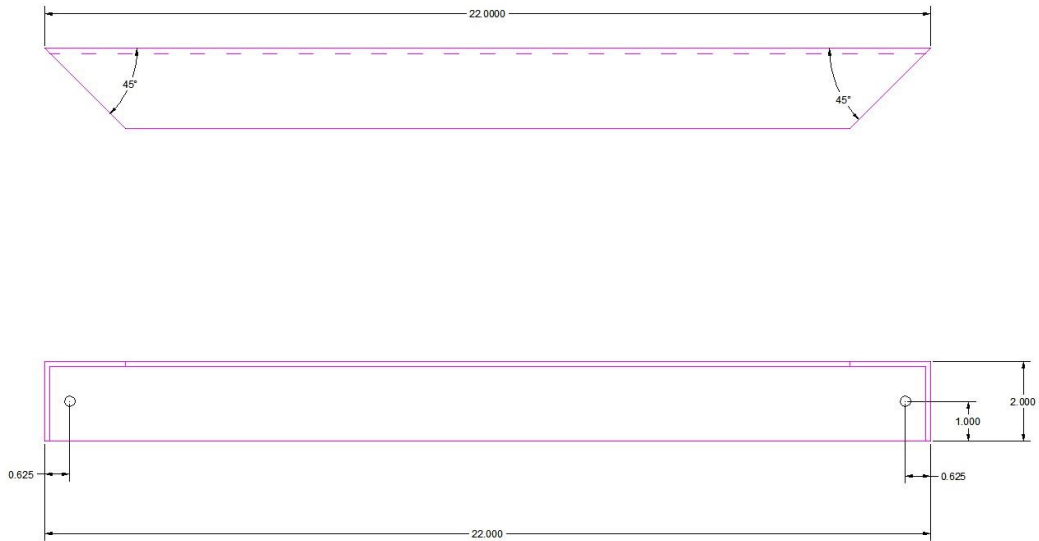

Lower Shelf Bracket (4)

5. Drill the holes for the four 96" tower legs. The three 0.295 inch diameter holes are repeated on **both sides** of each leg, in the same positions down from the top and in from the edge. The larger holes (0.345 inch diameter) are for mounting the feet at the bottom of each leg. Two legs have these holes on one side of the leg and two legs have them on the other side of the leg. (see the assembly manual for photos) This allows the tower to hinge on the feet.

Locations of holes in tower legs

Position of hole from top of leg	Diameter of hole (approximate)	Distance from top/bottom edge	Distance in from edge of leg	Notes
1	0.296	0.710 From top	1.00	Attachment to thrust bearing bracket
2	0.296	42.579 From top	0.541	Attachment to upper shelf brackets
3	0.296	65.807 From top	0.568	Attachment to lower shelf brackets
4	0.345	0.625 from bottom edge	1.00	Attachment to feet

6. Drill the holes in each tower foot as shown. The 0.375 inch diameter holes may be drilled larger in order to accept 3/8" bolts which are normally used to attach the feet to the roof (not included).

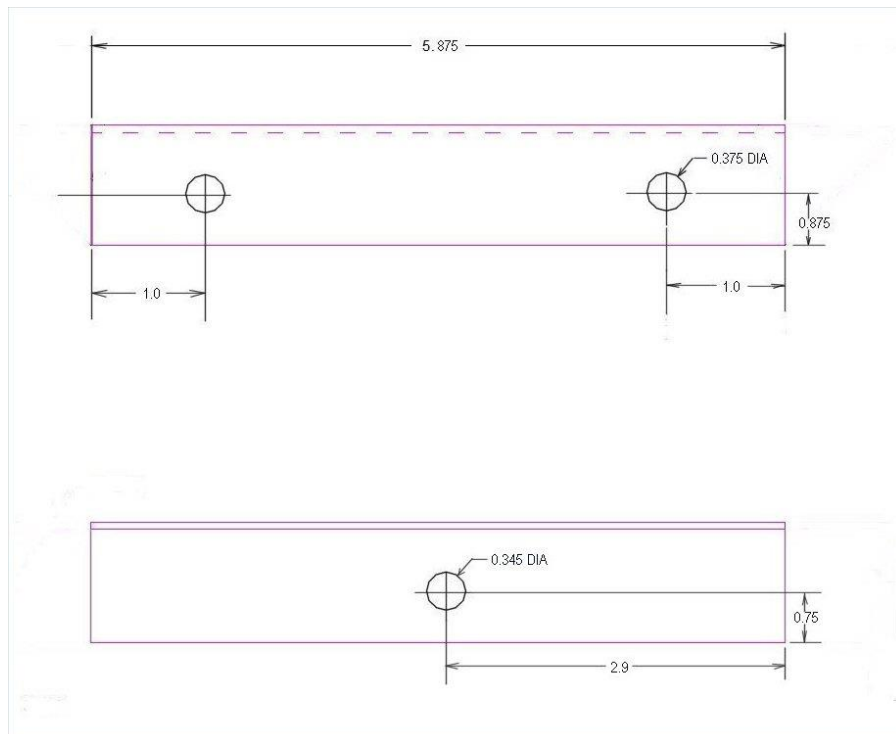

Tower Foot (4)

7. Drill the holes for the eight diagonal braces as shown. End holes are 0.296 dia. Center hole may be larger.

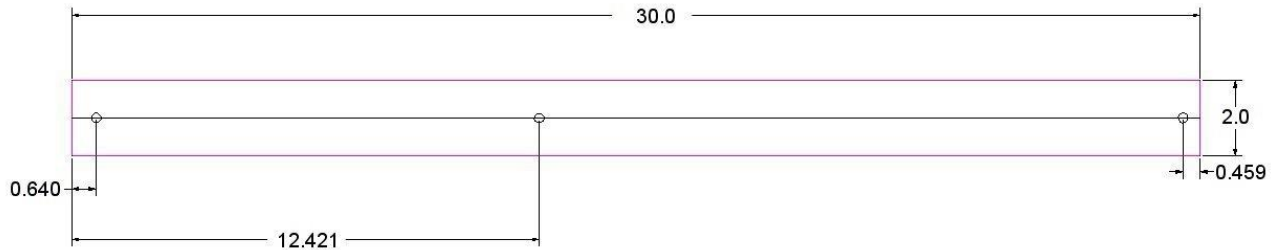

Diagonal Brace (8)

8. The hole diameter tolerances are ± 0.015 inch. The dimension tolerances are ± 0.030 inch. I recommend using calipers to scribe a line for dimensions less than 5 inches. Use a tape measure for dimensions greater than 5 inches.
9. Deburr all of the holes with the deburring bit and cordless drill. Deburr all sharp edges on cut aluminum angles with a hand-file.
10. Download the Assembly/Installation Manual for the IO-810 roof tower from the W8IO web site and follow these instructions.

If you have any questions concerning these instructions, contact Roger W8IO at rgcox2@gmail.com or 616-850-0899 after 6 pm EST.