

## W8IO Rooftowers LLC

### 4.5 foot Roof Mount Tower DIY Instructions

13 April 2016



#### TOOLS

First, you will need the following tools at a minimum:

1. 1/2" drill press with these approximate bit sizes - 0.265", 0.295", 0.312", 0.345", 0.375",
2. Table mounted miter saw with a 60 tooth (minimum) 10" carbide tipped blade
3. Tape measure
4. Calipers (either dial or digital)
5. Flat hand file
6. Hand cordless drill with deburring bit

Here is a good video which helps understand how to cut aluminum with a regular miter saw:

<http://www.youtube.com/watch?v=iojOYZw2Vi4>

## Bill of Material (B.O.M.)

The following aluminum angle and flats can be purchased from OnlineMetals.com.

1. 6 each 2" x 2" x 1/8" x 60" long 6061-T6 angle
2. 1 each 2" x 2" x 1/4" x 24" long 6061-T6 angle
3. 4 each 1/8" x 2" x 48" flat 6061-T6



The following hardware can be purchased from [Fastenal](#), [DX Engineering](#) or your favorite hardware store:

1. 1/4" - 20 x 1" length stainless steel bolt, Qty = 24
2. 1/4" - 20 x 3/4" length stainless steel bolt, Qty = 8
3. 5/16" - 18 x 1" length stainless steel bolt, Qty = 4
4. 1/4" SS split lockwashers, Qty = 32
5. 5/16" SS split lockwashers, Qty = 4
6. 1/4" SS hex nut, Qty = 32
7. 5/16"-18 SS hex nut, Qty = 4
8. 3/8" - 16 x 9" galvanized bolt or SS bolt for roof mounting (approx. length), Qty = 8
9. 3/8" lockwashers, Qty = 8
10. 3/8" - 16 hex nut (SS or galv.), Qty = 8

You will also need a thrust bearing for the top - either the [Yaesu GS-065](#) or [GS-050](#). The GS-065 will handle 2.5 inch diameter masts while the GS-050 will only handle up to 2.0 inch diameter masts. They have slightly different mounting-hole dimensions.

## CUTTING

Four of the 2" x 2" x 1/8" x 60" angles will be used for both the 54" legs and the 4.875" thrust bearing brackets. On each of these, begin with a 45 degree cut from the edge of the part inward. From the tip of this cut edge, measure 4.875" and mark. Cut on the mark with another 45 degree cut in the opposite direction - toward the previous cut. **Hint: Cut just past the mark so you have the correct length after the cut.** On the remaining long piece, measure 54" from the uncut end

and make a mark. Make a square cut at this mark to make the 54" leg. **Repeat this process 3 more times so that you have 4 legs and 4 thrust bearing brackets.** The cut side of the angle on the thrust bearing brackets will be trimmed to allow a 2.5" diameter mast tube. See the drawing of the thrust bearing bracket.

Each of the remaining 2" x 2" x 1/8" x 60" angles is cut into 3 each 17.5" long parts, two with 45 degree inward cuts at each end and one with straight cut ends. Begin with a 45 degree cut (from the right edge of the part inward), then from this cut edge, measure 17.5" and mark. Cut on the mark with another 45 degree cut (toward the right). Cut another 45 degree cut from the cut edge to the left to begin the second part. Measure 17.5" and mark. Cut on the mark with another 45 degree cut (toward the right). Measure 17.5" from the left edge and mark. Cut straight on this mark to make the third and final part from this length. **Hint: Cut just past each mark so you have the correct length after the cut.** The two 60" lengths make 6 parts – 4 lower shelves and 2 rotor shelves.



The 2" x 2" x 1/4" x 24" long angle is cut into 4 equal length sections with straight cuts. These are the 4 tower Feet, approximately 6" in length.



Each 1/8" x 2" x 48" flat piece is cut into 2 each 20" lengths with straight cuts, ending up with 8 each 1/8" x 2" x 20" flat pieces. These are the diagonal "X" braces.

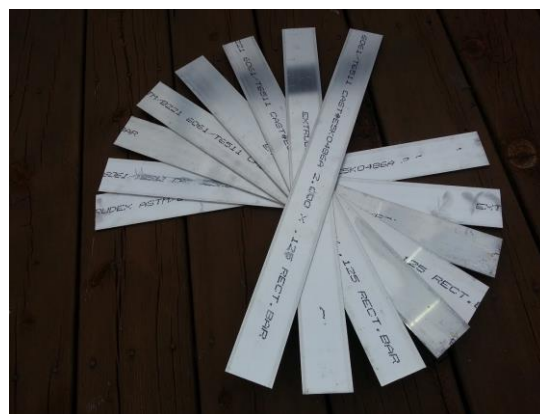

## DRILLING

Please carefully follow these steps to properly drill the holes for your 4.5 foot roof mount tower parts.

1. The top thrust bearing brackets should be drilled as shown below. The bracket is shown in the drawing as 5.0" in length. It fits together much easier if the length is closer to 4.875".

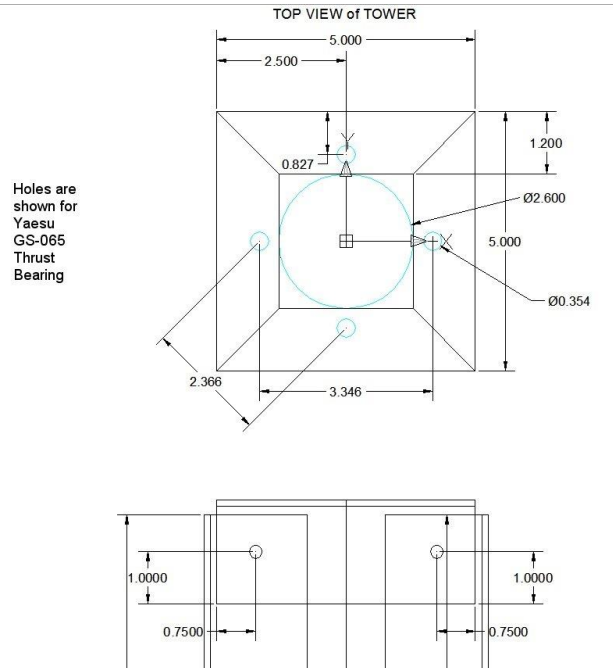

2. The four Lower Shelves are divided into two groups of two. Two shelves have holes drilled for attachment to the Legs and the Rotor Shelf. The two remaining Lower Shelves only have the holes drilled for attachment to the Legs. See the two drawings below.

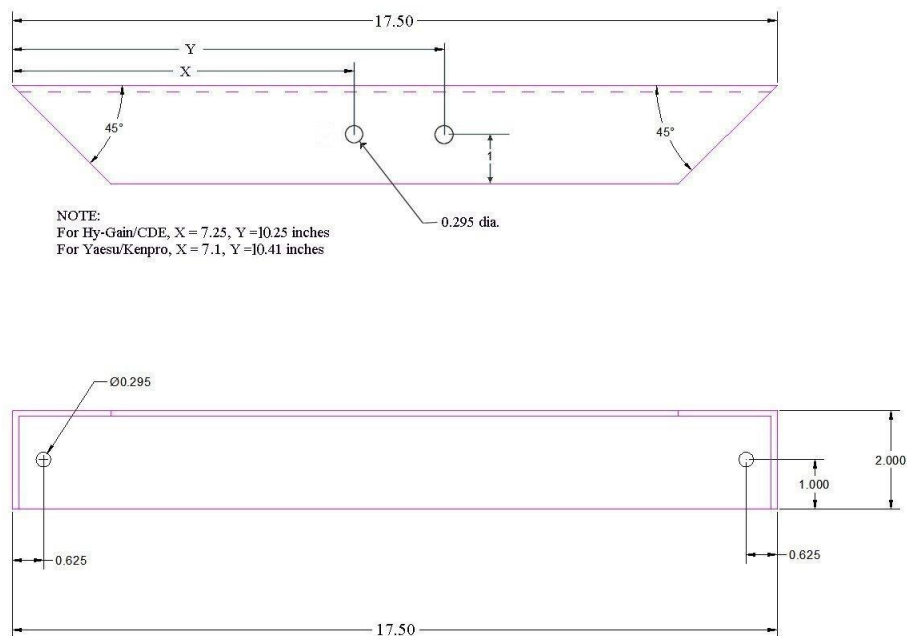

Lower Shelf with Rotor Shelf Mounting Holes (2)

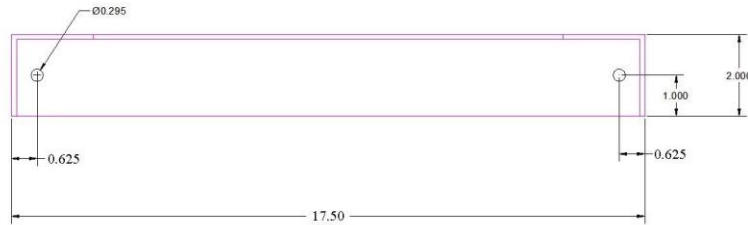
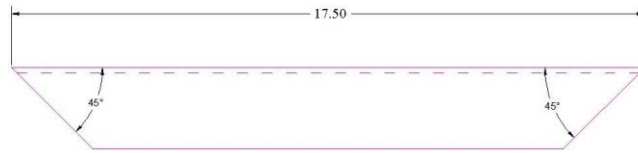

Lower Shelf (2)

3. Drill the holes for the Rotor Mounting Brackets as shown below.

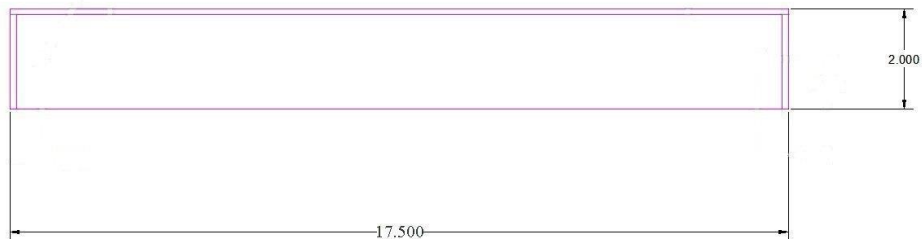
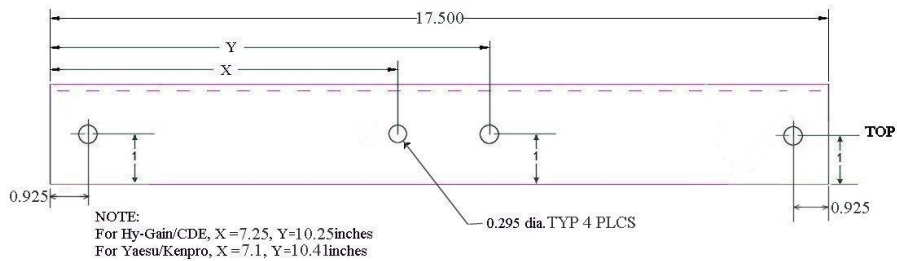

Rotor Mounting Bracket (2)

4. Drill the holes for the four tower legs. The three 0.295 inch diameter holes are repeated on **both sides** of each leg, in the same positions down from the top and in from the edge. The larger holes (0.345 inch diameter) are for mounting the feet at the bottom of each leg. Two legs have these holes on one side of the leg and two legs have them on the other side of the leg. (see the assembly manual for photos) This allows the tower to hinge on the feet.



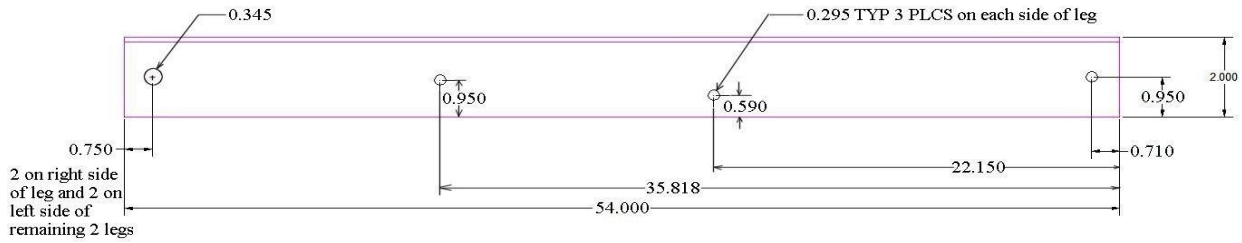

Tower Leg (4)

- Drill the holes in each tower foot as shown. The 0.375 inch diameter holes may be drilled larger in order to accept 3/8" bolts which are normally used to attach the feet to the roof (not included).

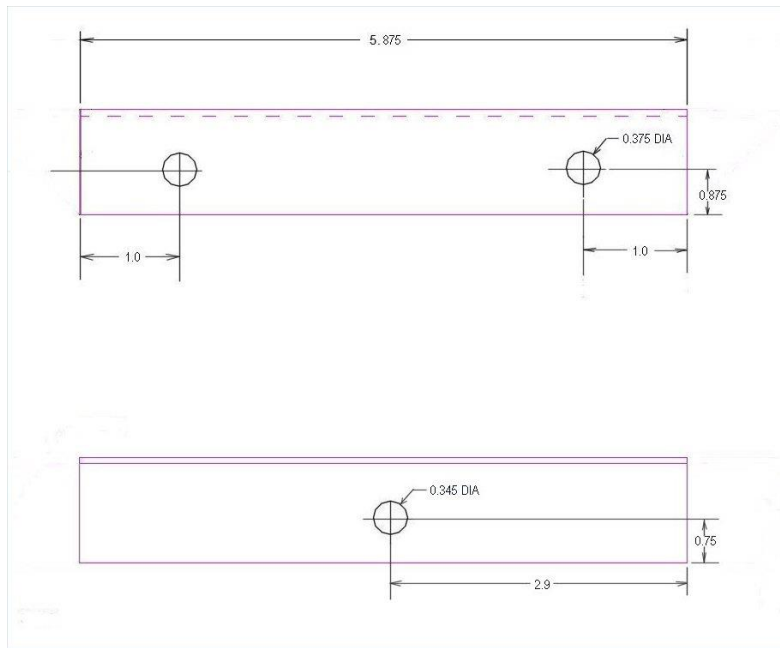

Tower Foot (4)

- Drill the holes for the eight diagonal braces as shown.

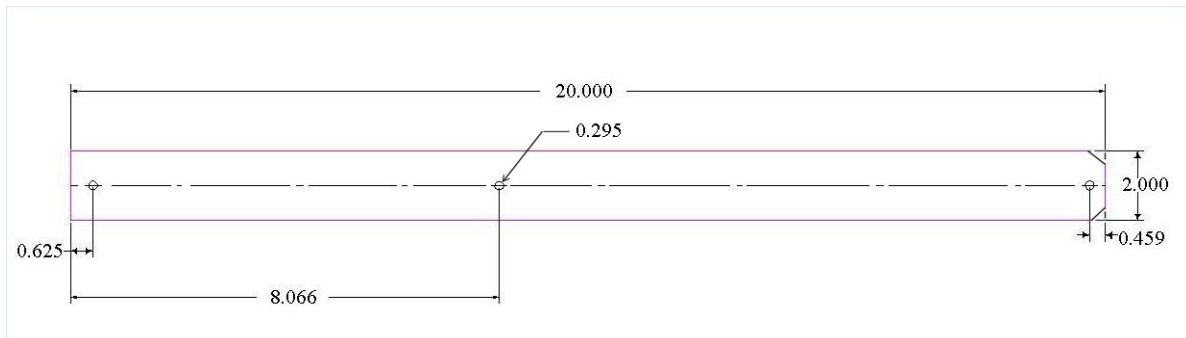

Diagonal Brace (8)

7. The hole diameter tolerances are +/- 0.015 inch. The dimension tolerances are +/- 0.030 inch. I recommend using calipers to scribe a line for dimensions less than 5 inches. Use a tape measure for dimensions greater than 5 inches.
8. Deburr all of the holes with the deburring bit and cordless drill. Deburr all sharp edges on cut aluminum angles with a hand-file.
9. Download the Assembly/Installation Manual for the IO-45 roof tower from the W8IO web site and follow these instructions.

If you have any questions concerning these instructions, contact Roger W8IO at [rgcox2@gmail.com](mailto:rgcox2@gmail.com) or 616-850-0899 after 6 pm EST.